

JERZY MICHALCZYK*, GRZEGORZ CIEPŁOK*

**MAXIMAL AMPLITUDES OF VIBRATIONS OF THE SUSPENDED SCREENS,
DURING THE TRANSIENT RESONANCE**

**AMPLITUDY MAKSYMALNE DRGAŃ PRZESIEWACZY PODWIESZONYCH
PODCZAS REZONANSU PRZEJŚCIOWEGO**

A usefulness of known methods for estimations of maximal amplitudes of suspended vibrating screens, in the transient resonance, was analysed in the paper. The way of adapting – for this type of machines – the new, developed by the authors, methods of analysing the transient resonance was indicated. Their accuracy was estimated by comparing the obtained results with the results of simulation investigations performed on the model, which takes into account the influence of the body vibrations on the vibrator motion.

Keywords: vibrating screens, systems of limited excitations, transient resonance

W pracy poddano analizie przydatność znanych metod dla oceny maksymalnych amplitud w rezonansie przejściowym przesiewaczy typu podwieszonych. W szczególności wskazano sposób zaadaptowania dla tego typu maszyn nowych, opracowanych przez autorów, metod analizy rezonansu przejściowego i oceniono ich dokładność przez porównanie z badaniami symulacyjnymi wykonanymi na modelu uwzględniającym zwrotne oddziaływanie drgań korpusu na ruch wibratora.

Słowa kluczowe: przesiewacze wibracyjne, układy o ograniczonym wzbudzeniu, rezonans przejściowy

1. Introduction

Determination of maximal amplitudes in the transient resonance of vibratory machines, applied in ore processing, is of a key meaning for the proper operation of these machines under industrial conditions. Resonance amplitudes, exceeding often steady states amplitudes by one to two orders, can cause failures of elastic support systems, knocking down material feed, collisions with cooperating devices and even hazards for health and life of employees.

Computational determination of these values is not easy and it is currently usually performed on the bases of inaccurate calculation models.

* AGH UNIVERSITY OF SCIENCE AND TECHNOLOGY, FACULTY OF MECHANICAL ENGINEERING AND ROBOTICS, AL. A. MICKIEWICZA 30, 30-059 KRAKOW, POLAND

2. Object and aim of the analysis

The object of analysis constitutes the typical mining vibration screen, suspended type, presented schematically in Figure 1.

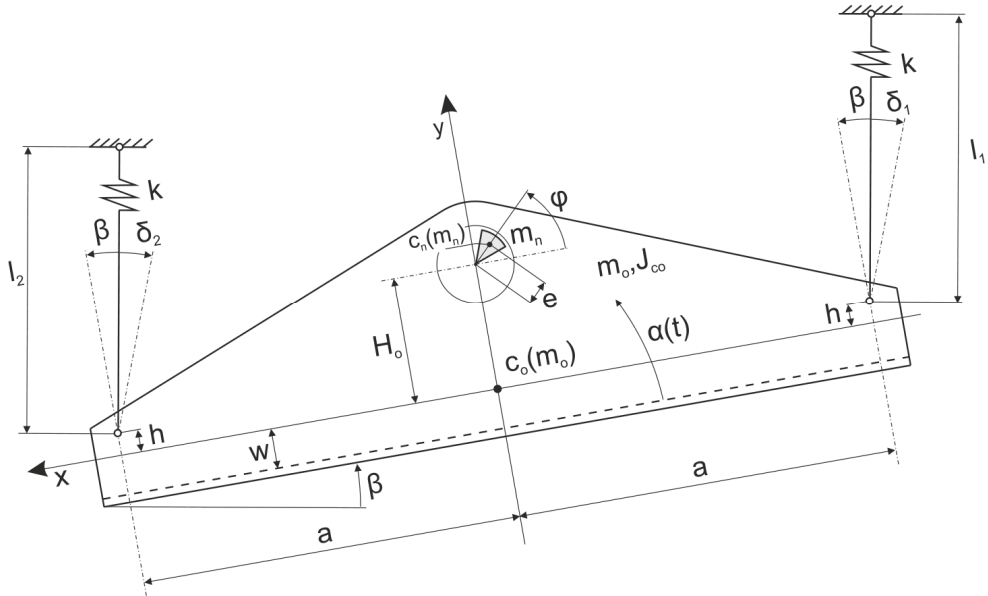

Fig. 1. Schematic presentation of the suspended screen

where:

- m_o, J_{co} — mass and central moment of inertia of the machine body with not rotational vibrator elements,
- c_o — mass centre of m_o ,
- m_n, e — unbalanced vibrator mass and its eccentric,
- c_n — mass centre of m_n ,
- k — elastic constants of the suspension system,
- β — riddle inclination angle,
- δ_i — out of plumb angles during vibrations, $i = 1, 2$,
- x, y, α — absolute co-ordinate system, assumed in the system static equilibrium, used for determining coordinates $x(t), y(t)$ of the mass centre c_o and angle of rotation $\alpha(t)$ of the machine body,
- φ — vibrator angle of rotation, in the absolute co-ordination system (as in Fig. 1),
- l_1, l_2 — total length of the suspension at the system static equilibrium,
— remaining notations as in Figure.

The aim of the analysis is the selection of the most proper method of the maximal amplitudes determination under transient resonance conditions and its adaptation for this machine type.

3. Methods of the transient resonance analysis

3a. Models of the given angular frequency course of the excitation force

The linear harmonic oscillator of one degree of freedom is the basic model applied currently in determining the maximal amplitudes (Fig. 2). The excitation force originated from the rotor unbalancing is here modelled as the *a priori* given harmonic force $P(t)$ of a variable frequency.

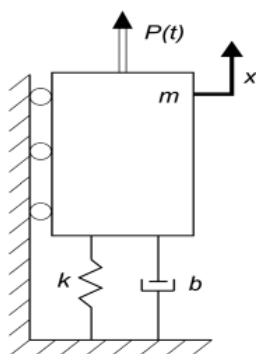

Fig. 2. Calculation model

The first solutions for such system were given in papers (Lewis, 1932; Kac, 1947; Bogusz, 1958). The mentioned classic solutions as well as the majority of later works (Turkiewicz & Banaszewski, 1982; Markert & Seidler, 2001) were based on the simplified version of equation of motion (1), assuming the knowledge of the rotor angular velocity and assuming its form as the linear-variable over time $\dot{\varphi}(t) = \omega(t) = \omega_0 \pm \varepsilon t$:

$$m\ddot{x} + b\dot{x} + kx = P \sin\left(\varphi_0 + \omega_0 t \pm \frac{\varepsilon \cdot t^2}{2}\right) \quad (1)$$

where $\varepsilon = \text{const}$, ((+) for start-up, (-) for coasting).

In classic solutions, described by equation (1), the excitation force component related to the rotor angular acceleration ε is omitted since in the resonance zone it is significantly smaller than the centrifugal force. In the first, historically, solution of the transient resonance problem (Lewis, 1932), the independence of the excitation force amplitude P from the rotor angular velocity was also assumed. The square dependence of the force amplitude of the rotor angular velocity $P = m\omega^2$, closer to the reality, was introduced by Kac (1947). To obtain the solution, usually the impulse transition function method and numerical calculations of some integrals or the integral equations method (Bogusz, 1958), were applied.

Later formulations of this problem were – in general – similar (except e.g. the work of Markert and Seidler (2001), who wrote the transient resonance equation in a way allowing for a more general description of $P(t)$, including the excitation force component related to the rotor

angular acceleration) and in a similar fashion as previous solutions, led to equations which main component was of a form:

$$A_{\max} \approx c \omega_n / \sqrt{\varepsilon} \quad (2)$$

where:

$$\omega_n = \sqrt{\frac{k}{m}} \quad (2a)$$

frequency of undamped system vibrations.

E.g. in the paper (Banaszewski, 1990) for the determination of maximal amplitudes during the coasting of vibrating screens the constant c in equation (2) was proposed as: $c = 1.8A_{\infty}$, where A_{∞} means the amplitude in the far over-resonant zone. This dependence contains a safety factor: 1.3, and therefore for the assessment of the *expected amplitude* the properly decreased value should be used: $c = 1.38A_{\infty}$.

Difficulty in the accurate assessing of the resonance amplitude by this method results from the fact, that the cited study recommends to assess angular acceleration values ε for the coasting from a wide range: 2 to 8.

Solutions obtained by analysing the model shown in Fig. 2 were used for constructing nomograms (Harris, 1957; Goliński, 1979), applied currently for determinations of maximal amplitudes in the transient resonance.

For systems of a larger number of degrees of freedom, such as in case of vibrating screens, the same methods are used, however after uncoupling the equations of motion (Bogusz, 1958; Golinski, 1979).

The fundamental flaw of these works, as far as real systems are concerned, is unknown angular acceleration value ε in the circum-resonant zone. This acceleration can not be determined on the bases of driving and anti-torque moments of the rotor, since it is – in reality – subjected to interactions with body vibrations. Thus, the proper model of the rotor machine (Fig. 3) constitutes the *model of a limited excitation* (Kononienko, 1964), of two degrees of freedom and described by the set of equations of motion (3):

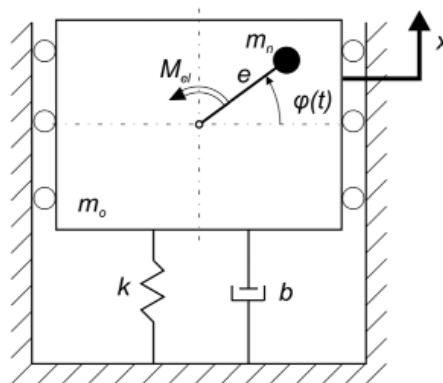

Fig. 3. Scheme of the rotor machine of a limited excitation

$$(m_o + m_n)\ddot{x} + b\dot{x} + kx = \dot{\varphi}^2 m e \sin \varphi - \ddot{\varphi} m e \cos \varphi \quad (3a)$$

$$J_{red} \ddot{\varphi} = M_{el} + M_w \quad (3b)$$

$$M_w = -\ddot{x} m_n e \cos \varphi \quad (3c)$$

where: m_o, m_n — mass of a machine body and of a vibrator – respectively, e — vibrator eccentric, J_{red} — moment of inertia of the driving system and vibrator reduced to the vibrator shaft, M_{el} — reduced engine driving moment decreased by anti-torque moments in vibrator bearings and power transmission elements.

The decisive influence on the rotor angular acceleration ε in the circum-resonant zone, has component M_w (3c) (occurring in the rotor equation of angular motion (3b)) called *vibratory moment* (Blechman, 1994), originated from rotor axis vibrations (increasing in the resonance). This component is of a strong braking torque character and causes that the real value of the angular acceleration is different (e.g. in the coasting much higher) than it would result from resistances to motion. It causes that maximal amplitude values determined from classic nomograms are – for the coasting – even several times overstated (Michalczyk, 1995).

3b. Energy-based models

The influence of the vibratory moment was taken into account in papers (Michalczyk, 1995, 2012), based on the system energy balance, obtaining ‘from the top’ estimations of maximal amplitudes. The kinetic energy of vibrators unit in the time instant of its entering the resonance zone of the i -th vibration form was, in these papers, equated to the vibration energy of the machine performing motions according to this vibration form.

According to this method the energy balance for the i -th resonance of the n -drive machine is of a form:

$$n \cdot \frac{1}{2} J_{red} \omega_{0i}^2 = \frac{1}{2} \dot{\mathbf{q}}_{\max i}^T \cdot \mathbf{M} \cdot \dot{\mathbf{q}}_{\max i} \quad (4)$$

where: ω_{0i} – angular velocity, at which the energy transfer occurs (in general, slightly different from the i -th natural frequency of the machine body on the elastic suspension system), $\mathbf{q} = \text{col}\{x_{s_i}, y_{s_i}, z_{s_i}, j_{x_i}, j_{y_i}, j_{z_i}\}$ – coordinates vector in the central co-ordinate system describing small body vibrations versus the static equilibrium position,

$$\mathbf{M} = \begin{bmatrix} m_c & 0 & 0 & 0 & 0 & 0 \\ & m_c & 0 & 0 & 0 & 0 \\ & & m_c & 0 & 0 & 0 \\ & & & J_{xx} & -J_{xy} & -J_{xz} \\ & & & & J_{yy} & -J_{yz} \\ & & & & & J_{zz} \end{bmatrix} \quad (5)$$

where \mathbf{M} is the system mass matrix, while J_{red} is the moment of inertia of the vibrator and its drive system reduced to the vibrator shaft.

For harmonic vibrations of frequency ω_{0i} the maximal values of generalised velocity $\dot{\mathbf{q}}_{\max i}$ are related to maximal amplitudes values of the displacement vector by the dependence: $\dot{\mathbf{q}}_{\max i} = \omega_{0i} \cdot \mathbf{q}_{\max i}$, which leads to the equation:

$$n \cdot \frac{1}{2} J_{red} \omega_{0i}^2 = \frac{1}{2} \omega_{0i}^2 \cdot \mathbf{q}_{\max i}^T \cdot \mathbf{M} \cdot \mathbf{q}_{\max i} \quad (6)$$

or after reduction:

$$n \cdot J_{red} = \mathbf{q}_{\max i}^T \cdot \mathbf{M} \cdot \mathbf{q}_{\max i} \quad (7)$$

Let it be assumed that vibratory motion of the machine body placed on elastic suspension system is described by the equation of small free undamped vibrations:

$$\mathbf{M} \cdot \ddot{\mathbf{q}} + \mathbf{K} \cdot \mathbf{q} = \mathbf{0} \quad (8)$$

where \mathbf{K} – symmetric elasticity matrix.

For the harmonic form of solutions $\mathbf{q} = \mathbf{q}_{\max} (\sin \omega t + \gamma)$, this leads to the matrix frequency equation (9)

$$[\mathbf{K} - \omega^2 \mathbf{M}] = \mathbf{0} \quad (9)$$

allowing to determine natural frequencies set ω_{0i} , $i = 1..6$ and modal vectors

$$Y_i(\omega_i) = \text{col}\{y_{1i}, y_{2i}, y_{3i}, y_{4i}, y_{5i}, y_{6i}\} \quad (10)$$

Let us assume for the moment, that these frequencies are different and sufficiently distant (in a sense of a circum-resonant vibration increasing). This allows to write the amplitudes vectors for the i -th frequency vibration in a form:

$$\begin{aligned} \mathbf{q}_{\max i} &= \left\{ \frac{\psi_{1i}}{\psi_{ki}} \cdot q_{\max ki}, \frac{\psi_{2i}}{\psi_{ki}} \cdot q_{\max ki}, \dots, q_{\max ki}, \dots, \frac{\psi_{6i}}{\psi_{ki}} \cdot q_{\max ki} \right\} \\ &= q_{\max ki} \text{col} \left\{ \frac{\psi_{1i}}{\psi_{ki}}, \frac{\psi_{2i}}{\psi_{ki}}, \dots, 1, \dots, \frac{\psi_{6i}}{\psi_{ki}} \right\} \end{aligned} \quad (11)$$

where: $q_{\max ki}$ — maximal amplitude, of the arbitrary selected to represent the i -th vibration form (at the assumption: $y_{ki} \neq 0$) of coordinate q_k .

Denoting

$$\text{col} \left\{ \frac{\psi_{1i}}{\psi_{ki}}, \frac{\psi_{2i}}{\psi_{ki}}, \dots, 1, \dots, \frac{\psi_{6i}}{\psi_{ki}} \right\} = \mathbf{a}_{ki} \quad (12)$$

and substituting the above into (11) and (7) we obtain finally the **dependence of the maximal amplitude of the k -th coordinate during the system passing through the resonance with the i -th natural frequency:**

$$q_{\max ki} = \sqrt{\frac{n \cdot J_{red}}{\mathbf{a}_{ki}^T \cdot \mathbf{M} \cdot \mathbf{a}_{ki}}} \quad (13)$$

This dependence constitutes the surplus estimation (in general, close to real values) of the maximal amplitude of the selected k -th coordinate in the i -th resonance, however under condition, that the vibrator excitation force performs work at vibrations of the tested form. This is an equivalent of the requirement that the appropriate modal force is not zero. Not meeting this condition should lead to passing through the resonance zone without excitations of machine vibrations. However, as it results from analytical considerations and simulation investigations (Michalczyk & Czubak, 2010), in the two-drive system of a free synchronisation of vibrators, such situation does not have to occur.

When multiple frequencies occur in the spectrum of natural frequencies, the above proceedings are usually impossible, on account of ambiguity of the vibrations form. The exceptions constitute symmetrical systems, which vibration form is known e.g. from the physical analysis (Michalczyk, 2012a).

This method can be also applied in relation to machines, which bodies require the description as the system of distributed parameters (Michalczyk, 2012b).

The energy balance was applied for the first time in paper (Agranovskaja & Blechman, 1969), however the vibrator kinetic energy was not compared to the body kinetic energy, but to the maximal potential energy of the suspension system. **The difficulty** of this version of the energy method is the necessity of determining the vibrator angular velocity at which the energy transfer occurs, while this velocity does not correspond directly to the system natural frequency (Lewis, 1932) and the method does not provide the way of its determination.

Limitations in applying both energy-based methods is the possibility of their application only in investigations of the machine free coasting and the fact that they determine the limited values of maximal amplitudes. The real maximal amplitudes values can be smaller than the limited values depending on the machine structure, drive system and resistance to motion.

3c. Methods taking into account the machine vibrations influence on rotor running, based on numerical solutions

The possibility of transformations of equations of motion of the symmetric machine model (Fig. 4) to the co-ordination system rotating with the unbalanced mass velocity, was indicated in paper (Cieplak, 2009).

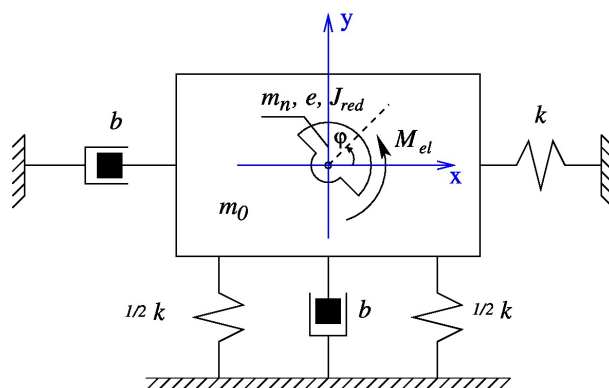

Fig. 4. Model of the symmetric machine. Notations as in Fig. 3.

This allowed to define relative units and to decrease twice the number of parameters describing the system motion, and then to develop – on the bases of broad simulation investigations – nomograms, for the determination of maximal amplitudes in transient states. The example of such nomogram for the determination of the ratio α of the maximal amplitude to the far over resonance amplitude in the steady state, for the machine free coasting, is shown in Fig. 5. The author indicated also (Cieplik, 2009 b), the possibility of using the above diagrams for machines of a linear trajectory, which requires only reading from the diagram for two times smaller value of parameter σ

where: $\alpha = \frac{A_{max}}{A_{\infty}}$

$$\sigma = \frac{m_n^2 e^2}{m J_{red}}, \quad \gamma = \frac{b}{2\sqrt{mk}}, \quad A_{\infty} = \frac{m_n e}{m}, \quad m = m_o + m_n \tag{14}$$

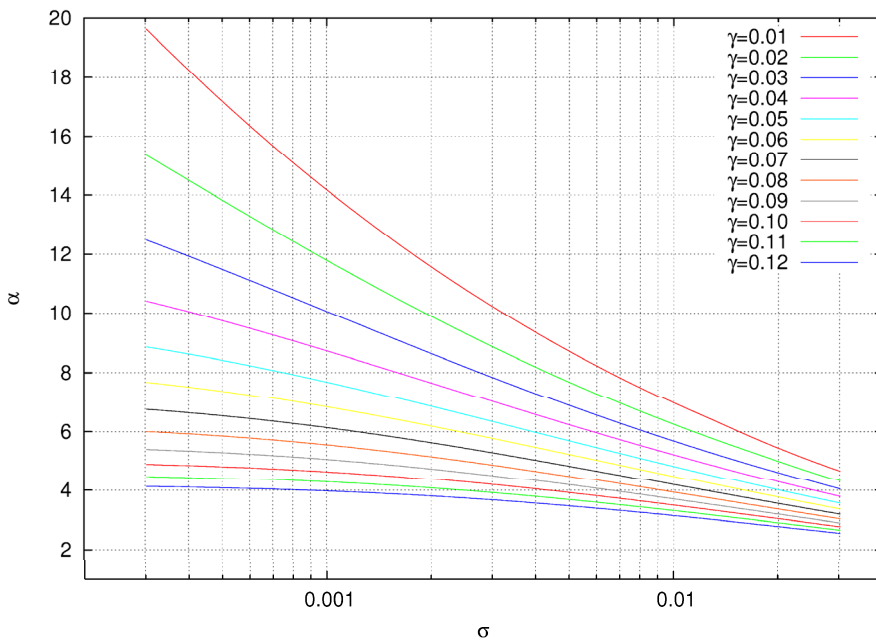

Fig. 5. Nomogram (Cieplik, 2009a) for the determination of maximal amplitudes at the free coasting of the symmetric machine and of the machine of a linear vibration trajectory.

For the case of the suppressed coasting and start-up, a more general form of monograms is given in (Cieplik, 2011).

Certain **difficulties** in practical applications of this methods, are listed below.

- 1^o In case of single-drive machines we are usually dealing neither with the symmetric type machine nor with the machine of a linear trajectory. If, however, the resonances occur at significantly different frequencies and have linear trajectories, then it is possible to act in a way described above.

- 2° In case of two-drive machines, it means classified as machines of a linear trajectory, during their coasting occur – in general – conditions leading to dissynchronising of drives (Michalczyk & Czubak, 2010), which changes the maximal amplitude in the working direction and causes an occurrence of resonance vibrations also in other directions.
- 3° This method does not give the answer in case of analysis of machine rocking vibrations, which usually correspond to the highest natural vibrations and high resonance amplitudes.

4. Simulation investigations

Simulation investigations performed on the model of the suspended vibrating screen were assumed as the *reference method*. The model was taking into account all essential features of real objects such as: non-linear character of the suspension together with the effect of ropes releasing, non-ideal character of the energy source including an influence of riddle vibrations on vibrator running, etc.

The most important advantage of the simulation model is the possibility of testing the behaviour of systems having various values of structural parameters (in a wide range) and the exact knowledge of parameters difficult to be determined in real objects. It especially concerns effects related to energy dissipations in the drive and suspension systems, which are changing with temperatures and random factors.

4a. Dynamic equations of the screen motion

The system shown in Fig. 1 was described by equations of motion:

$$m_o \ddot{x} = P_x + m_o g \sin(\beta) + S_{x1} + S_{x2} \quad (15a)$$

$$m_o \ddot{y} = P_y - m_o g \cos(\beta) + S_{y1} + S_{y2} \quad (15b)$$

$$J_{co} \ddot{\alpha} = P_x H_o + M_o + S_{x1} h + S_{x2} h + S_{y1} a - S_{y2} a \quad (15c)$$

$$m_n (\ddot{x} + \ddot{\alpha} H_o + \ddot{\varphi} e \sin(\varphi) + \dot{\varphi}^2 e \cos(\varphi)) = -P_x + m_n g \sin(\beta) \quad (15d)$$

$$m_n (\ddot{y} + \ddot{\varphi} e \cos(\varphi) - \dot{\varphi}^2 e \sin(\varphi)) = -P_y - m_n g \cos(\beta) \quad (15e)$$

$$J_{cn} \ddot{\varphi} = M - M_o + P_x e \sin(\varphi) + P_y e \cos(\varphi) \quad (15f)$$

where, apart from previous notations in Fig. 1, the following was assumed:

J_{cn} — central moment of inertia of unbalanced vibrator elements with the reduced moment of inertia of the engine rotor and power transition elements (it was assumed that the drive was separately placed on),

$$M_o = c \dot{\varphi}^2 \operatorname{sgn}(\dot{\varphi} - \dot{\alpha}) \text{ — resistance moment in vibrator bearings} \quad (16)$$

M — engine drive moment, usually sufficiently described by its static characteristics,

$M(\dot{\varphi})$ — (Giergiel, 1992), or obtained by solutions of dynamic equations of motion (Puchała, 1977),

P_x, P_y — components of vibrator interactions with the machine body,

S_{xi}, S_{yi} — components of ropes forces $S_i, i = 1, 2$,
– remaining notations as in Fig. 1.

Components of ropes tension were determined at the assumption, that:

$$a) \quad l_1, l_2 > 30A_{HR \max} \quad (17a)$$

$$b) \quad \text{static springs deflection} \cong \frac{mg}{2k} > A_{VR \max}, \text{ where: } m = m_o + m_n \quad (17b)$$

while $A_{HR \max}$ and $A_{VR \max}$ are maximal amplitude values of horizontal and vertical vibrations – respectively – of points at which the ropes were fixed to the body.

Then tensions S_1, S_2 of ropes l_1, l_2 can be determined from the dependencies:

$$S_{1lin} = k \left\{ 1 - \frac{\psi}{4} [1 - \text{sgn}(\dot{f}_1)] \right\} \left(\frac{mg}{2k} + f_1 \right),$$

$$S_1 = S_{1lin} \text{ if } S_{1lin} \geq 0, \quad S_1 = 0 \text{ if } S_{1lin} < 0 \quad (18a)$$

$$S_{2lin} = k \left\{ 1 - \frac{\psi}{4} [1 - \text{sgn}(\dot{f}_2)] \right\} \left(\frac{mg}{2k} + f_2 \right),$$

$$S_2 = S_{2lin} \text{ if } S_{2lin} \geq 0, \quad S_2 = 0 \text{ if } S_{2lin} < 0 \quad (18b)$$

where the suspension rope elongation from the static equilibrium position and their time derivative are described by approximate dependencies:

$$f_1 \cong -(y + \alpha a) \cos(\beta) + (x + \alpha h) \sin(\beta) \quad (19a)$$

$$f_2 \cong -(y - \alpha a) \cos(\beta) + (x + \alpha h) \sin(\beta) \quad (19b)$$

$$\dot{f}_1 \cong -(\dot{y} + \dot{\alpha} a) \cos(\beta) + (\dot{x} + \dot{\alpha} h) \sin(\beta) \quad (20a)$$

$$\dot{f}_2 \cong -(\dot{y} - \dot{\alpha} a) \cos(\beta) + (\dot{x} + \dot{\alpha} h) \sin(\beta) \quad (20b)$$

The description of elastic-damping forces of hysteresis type were assumed, acc. to (Michalczyk, 2008).

Tension force components are of a form:

$$S_{1x} = S_1 [-\sin(\beta + \delta_1)] \cong -S_1 [\sin(\beta) + \delta_1 \cos(\beta)] \quad (21a)$$

$$S_{2x} = S_2 [-\sin(\beta + \delta_2)] \cong -S_2 [\sin(\beta) + \delta_2 \cos(\beta)] \quad (21b)$$

$$S_{1y} = S_1 \cos(\beta + \delta_1) \cong S_1 [\cos(\beta) - \delta_1 \sin(\beta)] \quad (22a)$$

$$S_{2,y} = S_2 \cos(\beta + \delta_2) \cong S_2 [\cos(\beta) - \delta_2 \sin(\beta)] \quad (22b)$$

where out of plumb angles of ropes are determined as:

$$\delta_1 = [(x + ah) \cos(\beta) + (y + aa) \sin(\beta)] \frac{1}{l_1} \quad (23a)$$

$$\delta_2 = [(x + ah) \cos(\beta) + (y - aa) \sin(\beta)] \frac{1}{l_2} \quad (23b)$$

4b. The simulation investigations results

The following numerical data were assumed in simulations:

$$m_0 = 400 \text{ kg}, m_n = 20 \text{ kg}, e = 0.1 \text{ m}, J_{cn} = 0.26 \text{ kgm}^2, J_{red} = 0.46 \text{ kgm}^2, J_{co} = 150 \text{ kgm}^2, \\ k = 8.76 \cdot 10^4 \text{ N/m}, l_1 = l_2 = 0.85 \text{ m}, h = 0.05 \text{ m}, a = 0.8 \text{ m}, \beta = 20^\circ.$$

In relation to parameters essential from the point of view of the transient resonance – but not taken into account in the theoretical methods – or to parameters difficult for estimations, the simulations were carried out for the data intervals:

$$H_o = (0.00 \div 0.20) \text{ m}, c = (1 \div 3) \cdot 10^{-4} \text{ Nms}^2, \Psi = (0.040 \div 0.090).$$

The static characteristic of the deep-grooved engine was assumed in investigations for the driving moment description: $N = 1.5 \text{ kW}$, $n = 1000 \text{ rev/min}$.

As the simulation results the waveforms of individual coordinates containing the vibrator start-up, steady state and free coasting, were obtained. Examples of these waveforms obtained for average values of the above mentioned states, are shown in Fig. 6-9.

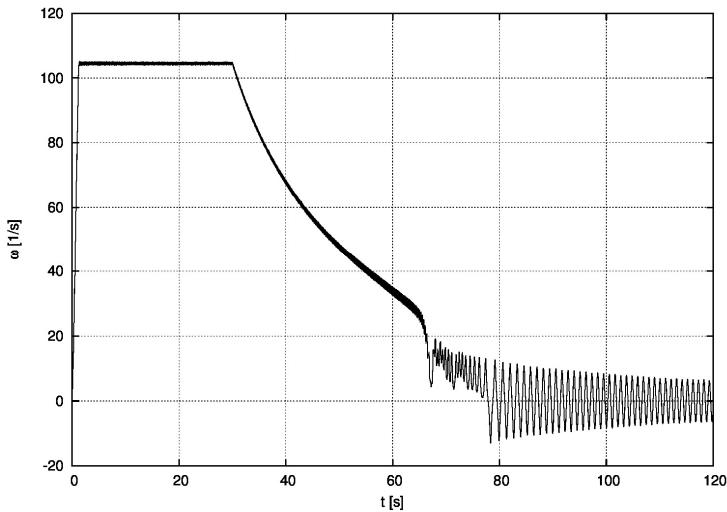

Fig. 6. Angular frequency course of the vibrator $\omega(t) = \dot{\varphi}(t)$

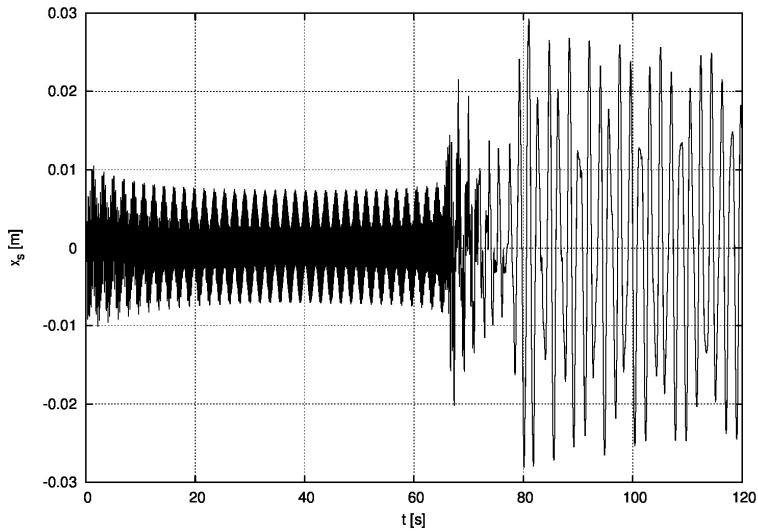

Fig. 7. Time-waveform of coordinate $x_s(t)$ of the body mass centre

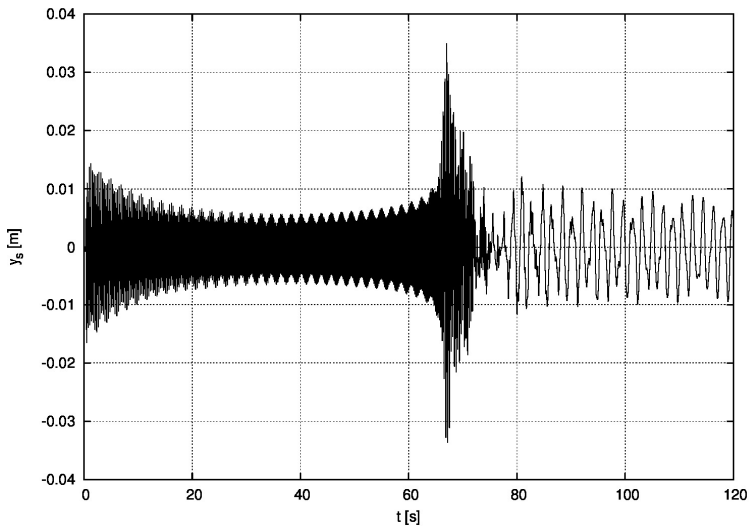

Fig. 8. Time-waveform of coordinate $y_s(t)$ of the body mass centre

On the basis of the above diagrams the maximal values of amplitudes in the transient resonance were determined – Table 1, for:

- body mass centre in direction x : $x_{s\max}$,
- body mass centre in direction y : $y_{s\max}$,
- body angular oscillations α : α_{\max} .

These data concern coasting amplitudes, since start-up amplitudes had smaller values.

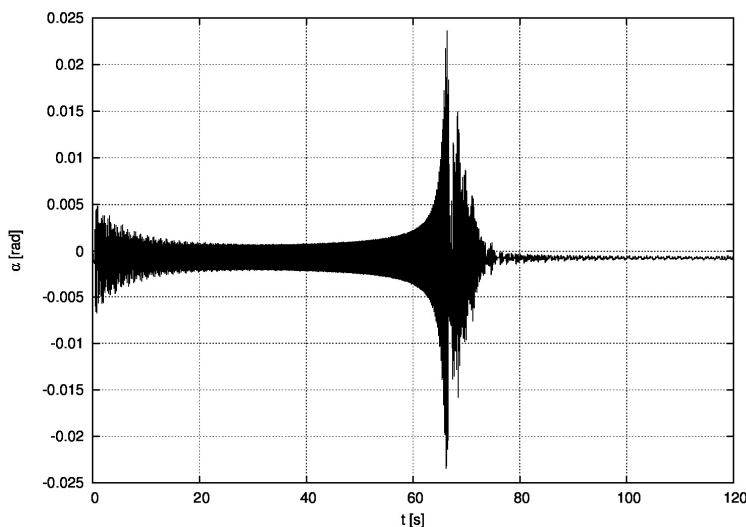

Fig. 9. Time-waveform of the body angular oscillations $\alpha(t)$

5. Determination of maximal amplitudes by theoretical methods

Due to faults of the classic method, described in item 2a, the energy-based (2b) and nomogram (2c) methods, applied for the analysis of the suspended vibrating screen, will be elaborated more precisely.

Energy-based method

In accordance with the principles of this method presented in item 2b, a point for departure constitutes the determination of main vibration forms of the system. Since the supporting system of suspended screens is, by its nature, non-linear this required linearization of the vibrating system model, which was possible due to the assumptions (17a) and (17b) met usually by typical structures. In addition, it was assumed, that the dependence – needed on account of working vibrations and the transient resonance – occurs:

$$h \cong \frac{m_n H_o}{m_o + m_n} \quad (24)$$

This equation assures uncoupling of vibrations into independent main forms, corresponding to *horizontal* (H), *vertical* (V) and *rotational* (α) vibrations.

Then dependence (13) takes – for these forms of vibrations – the following forms:

$$A_{H \max} = A_{V \max} = \sqrt{\frac{J_{red}}{m}} \quad (25)$$

$$A_{\alpha \max} \leq \sqrt{\frac{J_{red}}{J}} \quad (26)$$

where:

- J_{red} — moment of inertia of vibrator and rotation elements of the drive system, reduced to the vibrator shaft,
 $m = m_o + m_n$ — machine vibrating mass,
 J — moment of inertia of the machine body together with the vibrator, in relation to their common mass centre, at the concentration of the vibrator unbalanced mass in its axis of rotation.

The unevenness sign in (26) originates not only from the method character, which determines upper amplitude limits, but mainly from the fact that at certain conditions this amplitude can lead to very low values, even to zero. Low values of real amplitudes can occur e.g. in case of close position of the successive frequency, corresponding to vertical vibrations, while zero value can occur in case when parameters – responsible for the rocking form of vibrations – lead to zero: $H_o, h \rightarrow 0$.

Vibrations of individual forms occur around natural frequencies corresponding to these forms of vibrations:

$$\omega_H = \sqrt{\frac{g}{2} \left(\frac{1}{l_1} + \frac{1}{l_2} \right)}, \quad \omega_V = \sqrt{\frac{2k}{m}}, \quad \omega_\alpha = a \cos(\beta) \sqrt{\frac{2k}{J}} \quad (27)$$

Taking into account the values of constants, assumed in item 3b, it is possible to obtain the expected values characteristic for resonance vibrations during the machine coasting (see Table 1).

Nomogram method

Using the nomogram shown in Fig. 5 for the system performing – in the transient resonance – only vertical or horizontal motion, $1/2\sigma$ should be deposited on the horizontal axis, where σ was calculated acc. to (14). The equivalent damping value $\gamma_{H,V}$ for horizontal or vertical vibrations can be determined by calculating:

$$b_{H,V} = \frac{\psi \cdot k_{H,V}}{2\pi\omega_{H,V}}, \quad \gamma_{H,V} = \frac{b_{H,V}}{2\sqrt{m \cdot k_{H,V}}} \quad (28)$$

where:

$$k_H = m\omega_H^2, \quad k_V = 2k \quad (29)$$

The list of the most important results of simulation and analytical investigations concerning maximal amplitudes during the screen free coasting are given in Table 1 and Table 2, where the maximal amplitudes values – obtained by the analytical methods in the vertical V and horizontal H direction – were recalculated into displacements along x and y axis.

TABLE 1

Results of the simulation investigations for various structure constants of the machine, not taken into account in the theoretical analysis

No.	H_0 [m]	c [Nms ²] $\times 10^{-4}$	Ψ [-]	x_{\max} [m]	y_{\max} [m]	α_{\max} [rad]
1	0.0	1.0	0.04	0.0228	0.0317	0.0173
2	0.2	1.0	0.04	0.0269	0.0348	0.0473
3	0.0	3.0	0.04	0.0327	0.0391	0.0233
4	0.2	3.0	0.04	0.0241	0.0400	0.0448
5	0.0	1.0	0.09	0.0255	0.0297	0.0119
6	0.2	1.0	0.09	0.0207	0.0339	0.0336
7	0.0	3.0	0.09	0.0246	0.0289	0.0117
8	0.2	3.0	0.09	0.0301	0.0317	0.0328

TABLE 2

Confrontation of the results of the simulation investigations and theoretical analysis

Method	x_{\max} [m]	y_{\max} [m]	α_{\max} [rad]
Simulation	0.021÷0.033	0.029÷0.040	0.012÷0.047
Energy-based – eq. (25), (26)	0.031	0.031	≤ 0.055
Nomogram – Fig. 5	0.035	0.035	—
Classic – eq. (2) (Banaszewski, 1990)	—	0.044÷0.090	—

6. Conclusions

The conclusions drawn on the bases of the theoretical analysis and simulation studies are listed below.

1. Maximal amplitudes during the coasting of the suspended screens are – for typical constructions – larger than during the start-up. In the investigated cases they were larger 2 to 3.5 times.
2. Analytical determinations of maximal amplitudes during the coasting are difficult due to:
 - usually natural frequencies of the body rotational and vertical vibrations are in close positions (in the analysed case the frequency difference was: $\Delta f = f_a - f_v = 0.75$ Hz). This does not meet assumptions of the analytical methods (Michalczyk, 2012) and leads to the system escape from the rotational resonance to the vertical one, before a total evolving of the angular amplitude. Simultaneously the energy ‘taken out’ from the rotational resonance is transferred into the vertical resonance increasing its maximal amplitude. During these resonances ropes releasing can occur, which makes the suspension non-linear and does not fulfil assumptions of the analytical methods.
3. Approximate values of maximal amplitudes for the vertical and horizontal direction can be determined by two new methods described in the paper: energy balance and nomogram, from which the simulation results differ not more than:
 - for vertical vibrations: the energy-based method 6-29%, the nomogram method 14-17%,
 - for horizontal vibrations: the energy-based method 3-32%, the nomogram method 6-40%

4. Approximate value of the maximal amplitude of angular oscillations can be determined by the energy balance method, but obtaining by the system the maximal angular oscillations amplitude (given by eq. (26)), occurs only in non-central systems at adequately large H_o values, enabling energy transfer into this form of vibrations. Especially, when H_o and $h \rightarrow 0$, $A_{\alpha \max} = 0$, occurs.

In addition, in case of the close positions of natural frequencies f_{α} and f_{ν} , the system, due to reasons described above, does not evolve the total possible amplitude value of angular oscillations.

References

- Agranowskaja E.A., Blechman I.I., 1969. *Ob ocenke rezonansnykh amplitud kolebanii pri vybiegii sistema so mnogimi stepieniami swobody*. Dinamika Maszyn, Nauka, Moskwa.
- Banaszewski T., 1990. *Przesiewacze*. Wyd. Śląsk.
- Blechman I.I., 1994. *Vibracjonnaja Mechanika*. Nauka, Moskwa.
- Bogusz W., 1958. *Drgania fundamentów w czasie rozruchu silników wirnikowych*. Rozprawy Inżynierskie, t. XCVII
- Cieplak G., 2009a. *Stany nieustalone nadrezonansowych maszyn wibracyjnych*. UWND AGH, Kraków.
- Cieplak G., 2009b. *Verification of the nomogram for amplitude determination of resonance vibrations in the run-down phase of a vibratory machine*. Journal of Theoretical and Applied Mechanics, Vol. 47, No 2.
- Cieplak G., 2011. *Wpływ momentu hamującego na wartość amplitudy drgań rezonansowych podczas wybiegu maszyny wibracyjnej napędzanej wiratorem bezwładnościowym*. Czasopismo Techniczne, Politechnika Krakowska. Seria: Mechanika.
- Giergiel M., 1992. *Dobór parametrów układów hamowania nadrezonansowych maszyn wibracyjnych*. Rozprawa doktorska na Wydz. MGİH AGH Kraków.
- Goliński J., 1979. *Wibroizolacja maszyn i urządzeń*. WNT, Warszawa.
- Harris C. (red.), 1957. *Handbook of Noise Control*. Mc Graw-Hill BookCo., New York.
- Kac A.M., 1947. *Wyższionnyje kolebanija pri prochożdienii czerez riezonans*. Inżynieryj Sbornik, Wyp. 2, t. 3.
- Kononienko W.O., 1964. *Kolebatielnyje systemy s ograniczonym wozbużdienijem*. Nauka.
- Lewis F., 1932. *Vibration During Acceleration Through a Critical Speed*. Asme-Trans, Vol. 54.
- Markert R., Seidler M., 2001. *Analytically based estimation of the maximum amplitude during passage through resonance*. International Journal of Solids and Structures, Vol. 38, Iss. 10-13.
- Michalczyk J., 1995. *Maszyny wibracyjne – obliczenia dynamiczne, drgania, hałas*. WNT, Warszawa.
- Michalczyk J., 2008. *Phenomenon of Force Impulse Restitution in Collision Modelling*. Journal of Theoretical and Applied Mechanics, Vol. 46, No 4.
- Michalczyk J., Czubak P., 2010. *Methods of Determination of Maximum Amplitudes in the Transient Resonance of Vibratory Machines*. Archives of Metallurgy and Materials, Vol. 55, No. 3.
- Michalczyk J., 2012a. *Transient Resonance of Machines and Devices in General Motion*. Journal of Theoretical and Applied Mechanics, Vol. 50, No 2.
- Michalczyk J., 2012b. *Maximum Amplitudes in Transient Resonance of Distributed – Parameter Systems*. Archives of Mining Sciences, Vol. 57, No 3.
- Puchała A., 1977. *Dynamika maszyn i układów elektromechanicznych*. PWN, Warszawa.
- Turkiewicz W., Banaszewski T., 1982. *Wzrost amplitudy drgań podczas zatrzymywania przesiewaczy z napędami bezwładnościowymi*. Archiwum Górnictwa, Vol. 27, z. 4.